

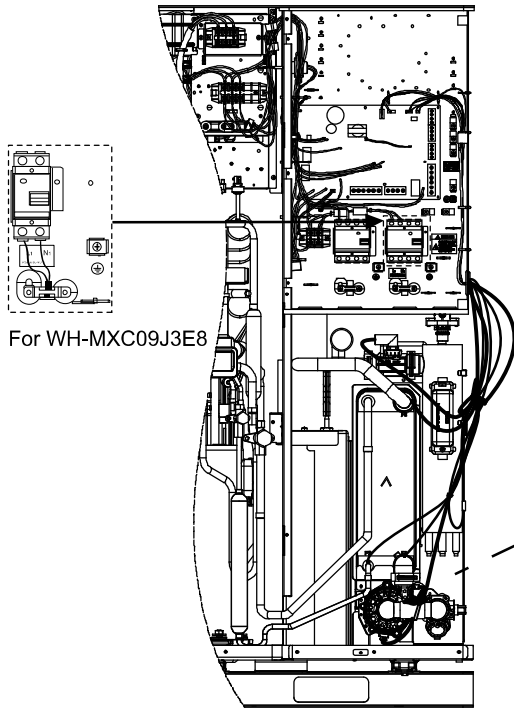

18.8 To Remove Water Pump

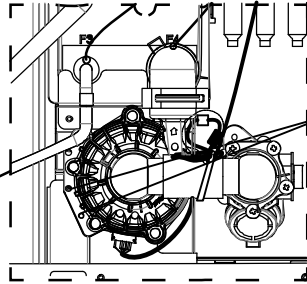



1. Disconnect CN-PUMP1 connector from Electronic Controller Board.

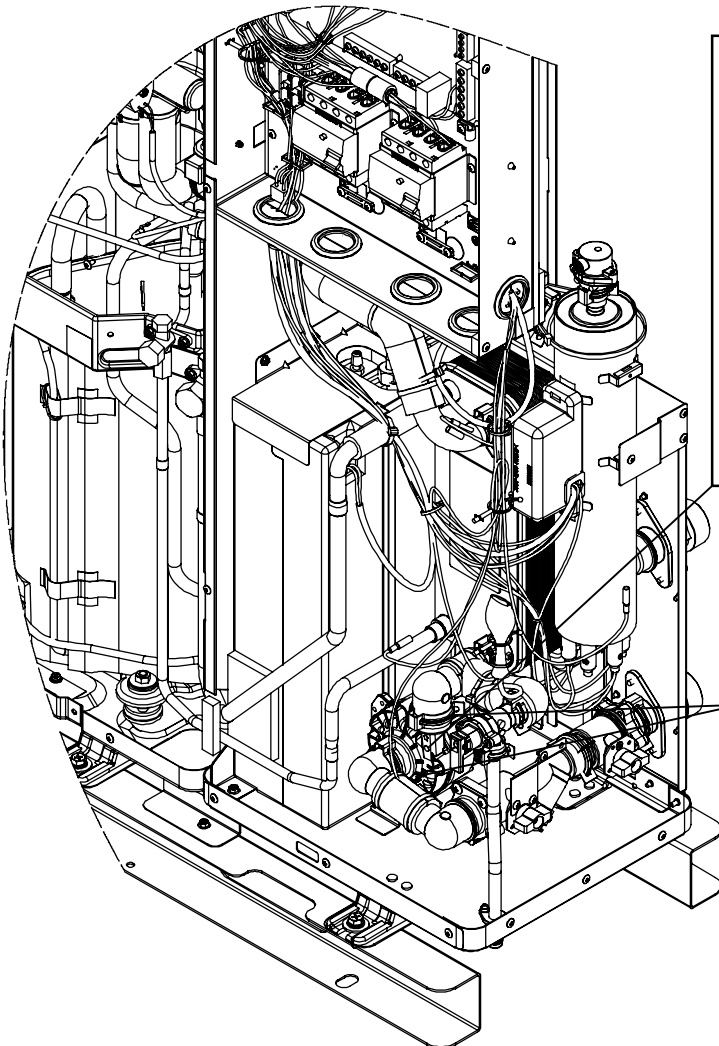

2. Remove 2 screw from Pump Bracket.

 When reinstall the water pipe, use grease or water at the joining.



 If pump is replace, please follow below instruction.

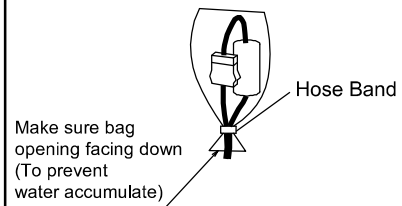

1. Please fix bag around the connector as shown, and seal it with a band.

3. Remove 2 retaining ring, then slowly pull out the water pump.

18.9 To Remove Heater

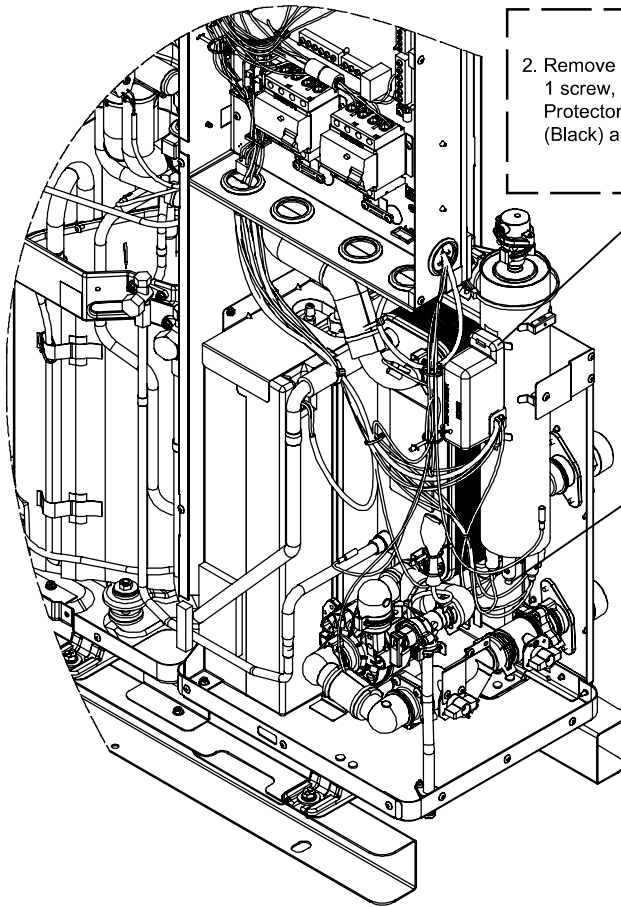

2. Remove terminal cover by releasing 1 screw, then remove the Overload Protector (OLP) lead wire (Blue), (Black) and (Orange).

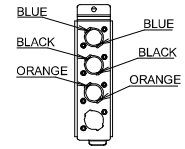

LEAD WIRE FIXING FOR OLP

1. Remove 4 lead wire, HT1-L2 (Orange), HT-L3 (Red) and AC2-N2 (White) and N1 (White) from below the Heater.

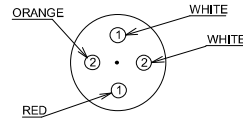

LEAD WIRE FIXING FOR HEATER

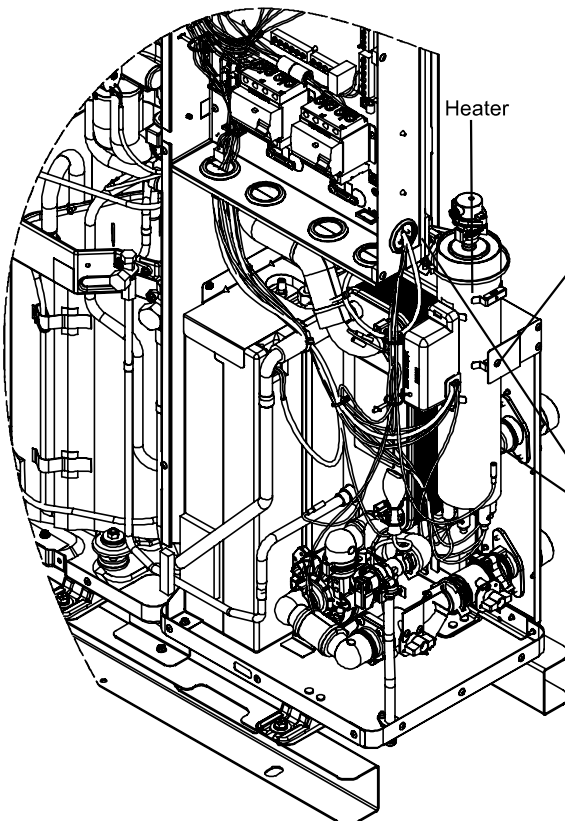

3. Remove 1 screw from the Heater Bracket

4. Release 2 retaining ring, and slowly remove the Heater Complete.

18.10 To Remove Filter

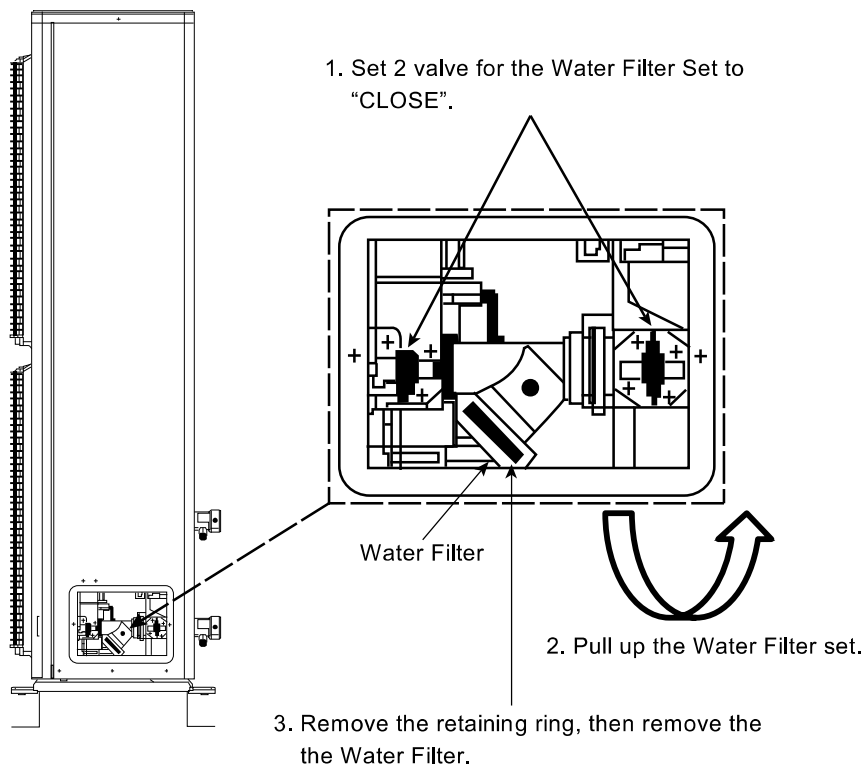
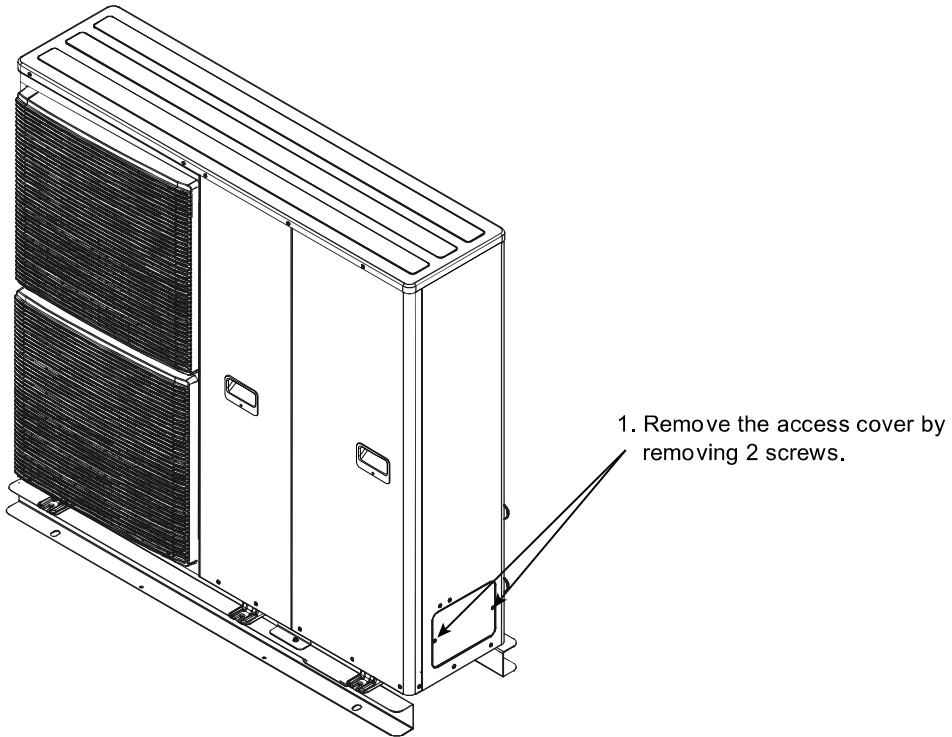

19. Technical Data

19.1 Operation Characteristics

19.1.1 WH-MXC09J3E8

Heating Characteristics at Different Outdoor Air Temperature

Condition

Outdoor air temperature : 7°C (DBT), 6°C (WBT)

Indoor water inlet temperature : 30°C

Indoor water outlet temperature : 35°C

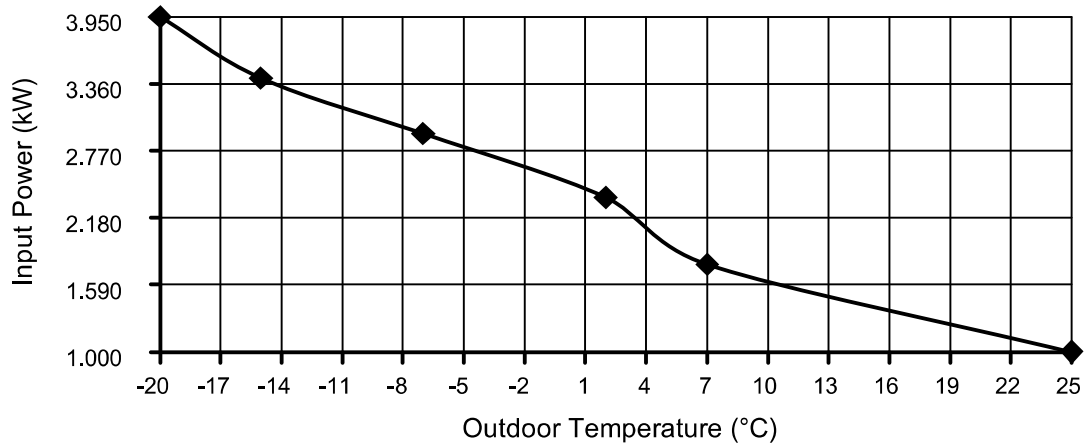
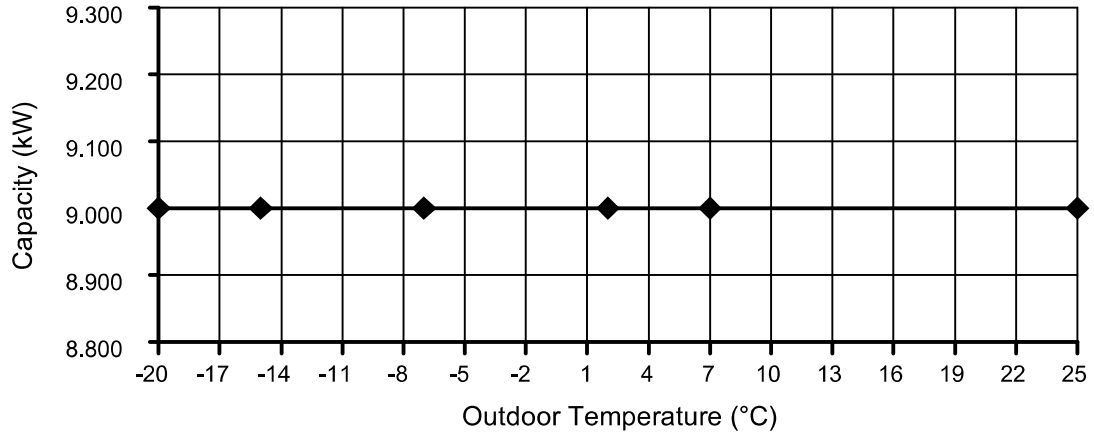

Cooling Characteristics at Different Outdoor Air Temperature

Condition

Outdoor air temperature : 35°C (DBT), -°C (WBT)

Indoor water inlet temperature : 12°C

Indoor water outlet temperature : 7°C

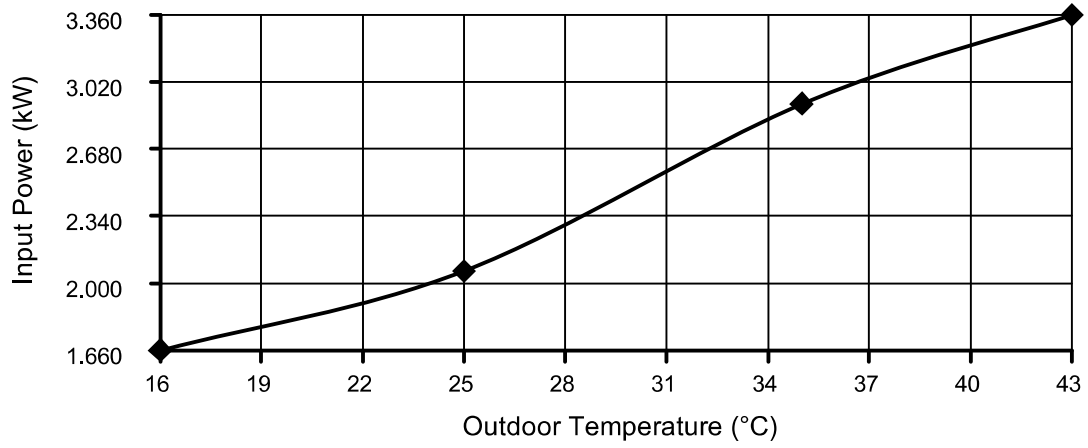
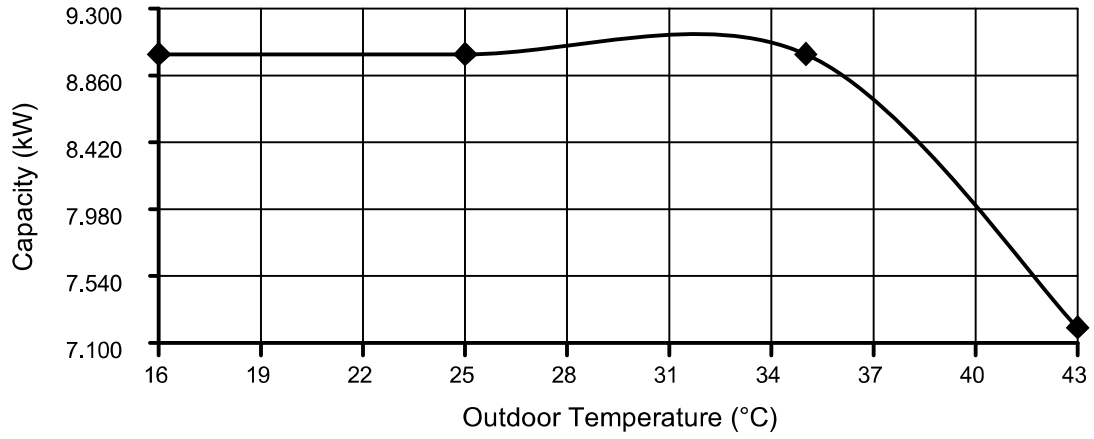

Cooling Characteristics at Different Outdoor Air Temperature

Condition

Outdoor air temperature : 35°C (DBT), -°C (WBT)

Indoor water inlet temperature : 19°C

Indoor water outlet temperature : 14°C

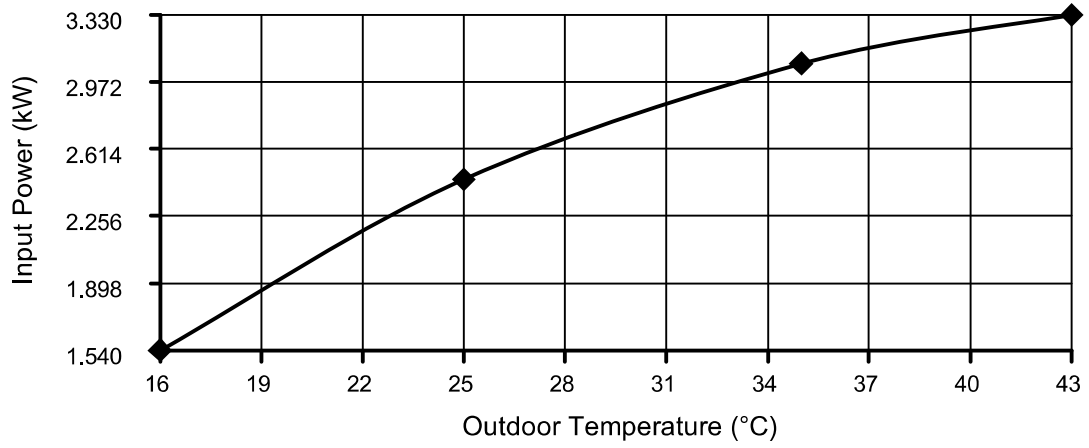
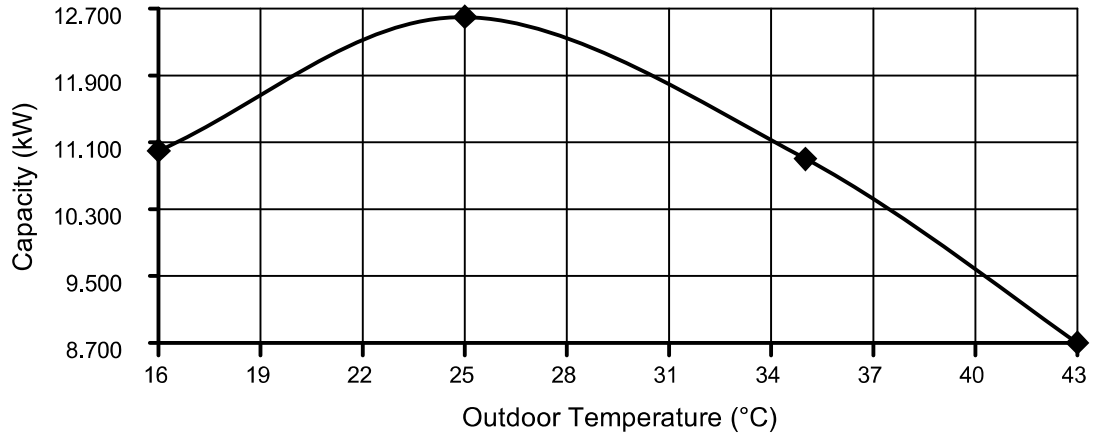

Cooling Characteristics at Different Outdoor Air Temperature

Condition

Outdoor air temperature : 35°C (DBT), -°C (WBT)

Indoor water inlet temperature : 23°C

Indoor water outlet temperature : 18°C

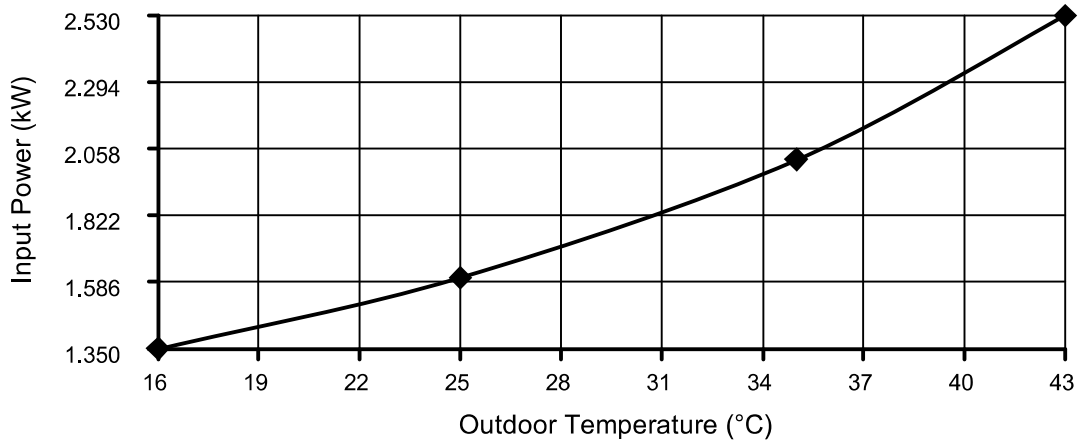
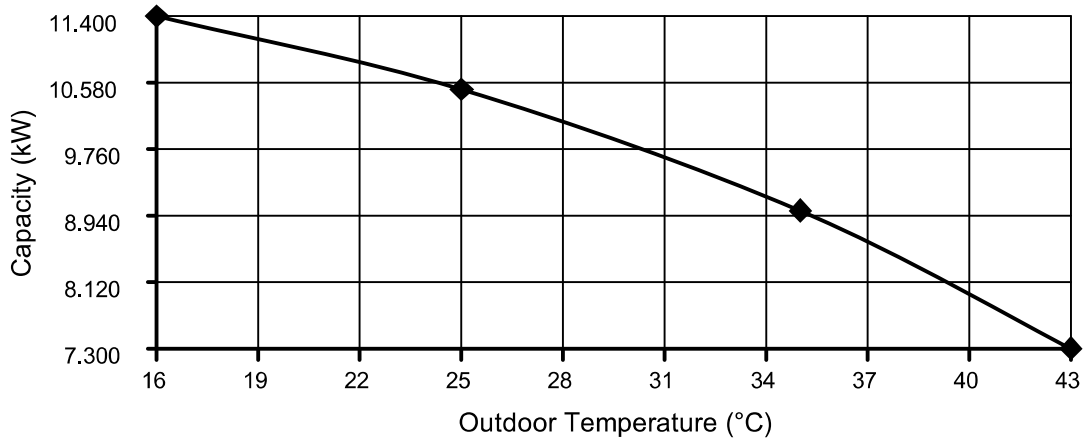

19.1.2 WH-MXC12J9E8

Heating Characteristics at Different Outdoor Air Temperature

Condition

Outdoor air temperature : 7°C (DBT), 6°C (WBT)

Indoor water inlet temperature : 30°C

Indoor water outlet temperature : 35°C

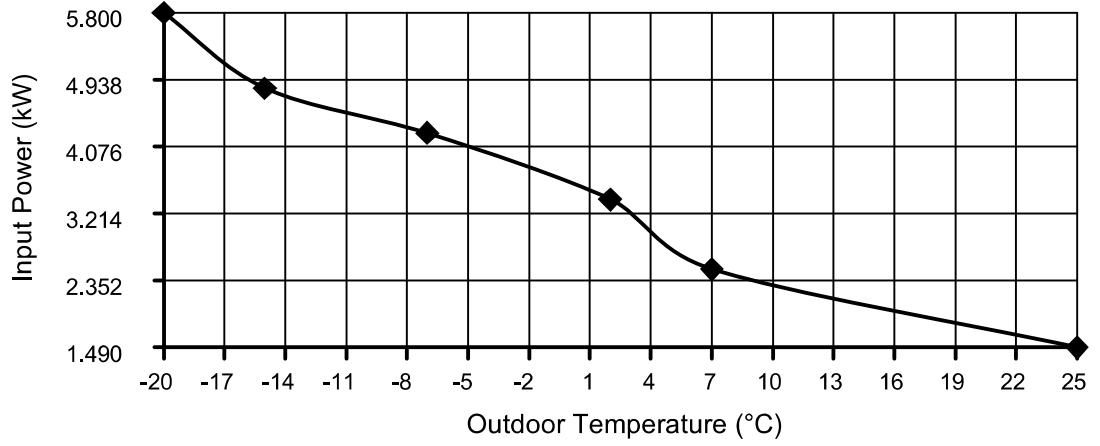
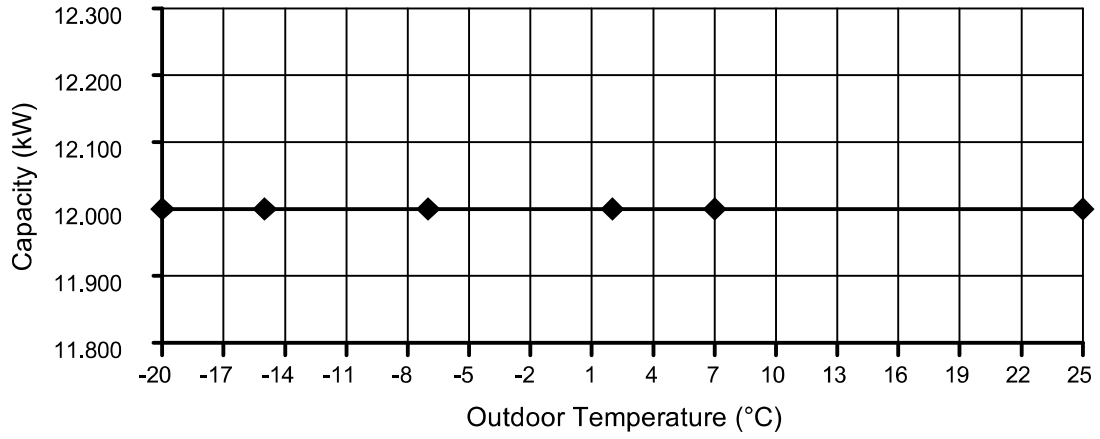

Cooling Characteristics at Different Outdoor Air Temperature

Condition

Outdoor air temperature : 35°C (DBT), -°C (WBT)

Indoor water inlet temperature : 12°C

Indoor water outlet temperature : 7°C

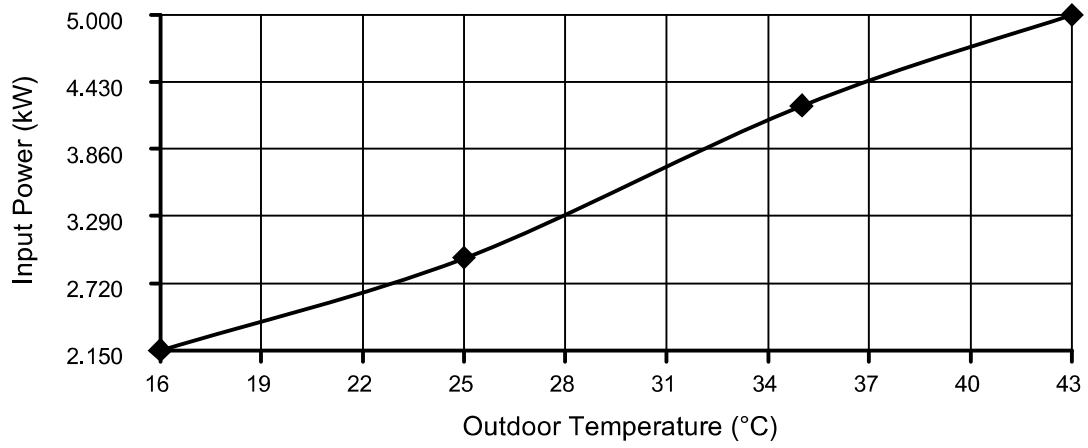
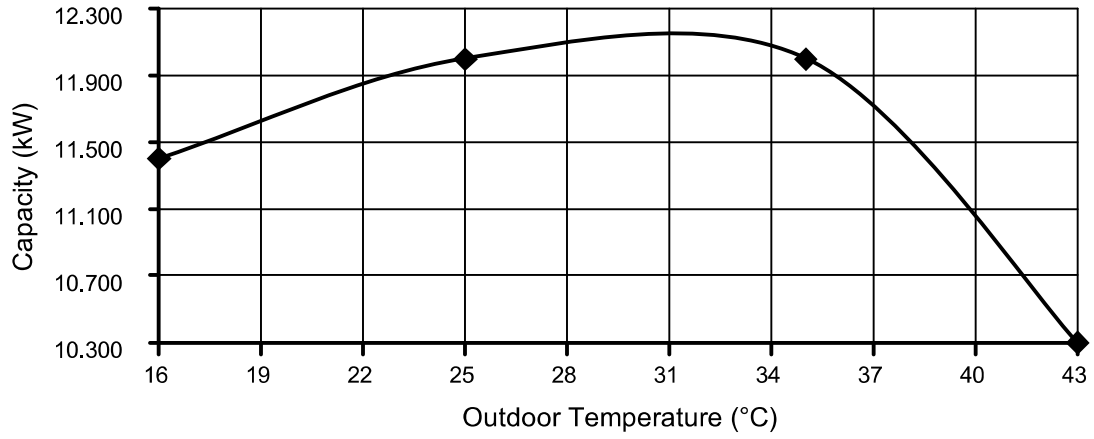

Cooling Characteristics at Different Outdoor Air Temperature

Condition

Outdoor air temperature : 35°C (DBT), -°C (WBT)

Indoor water inlet temperature : 19°C

Indoor water outlet temperature : 14°C

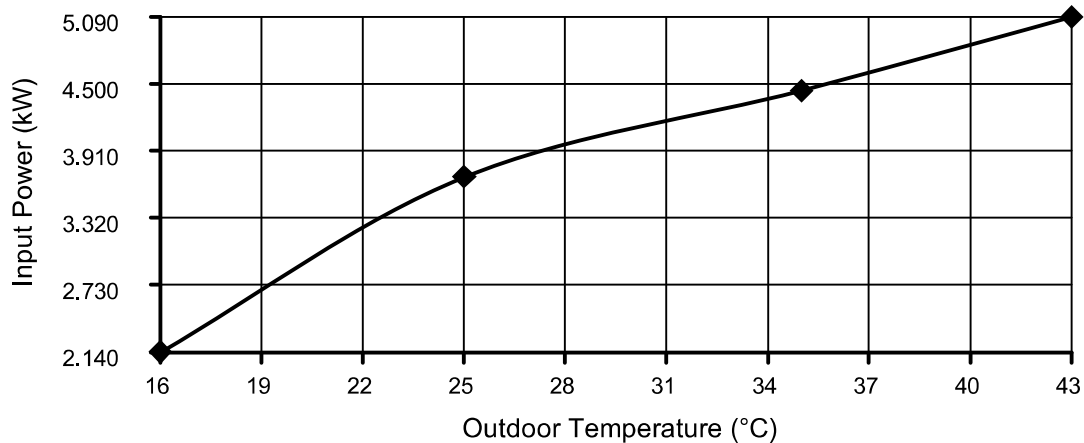
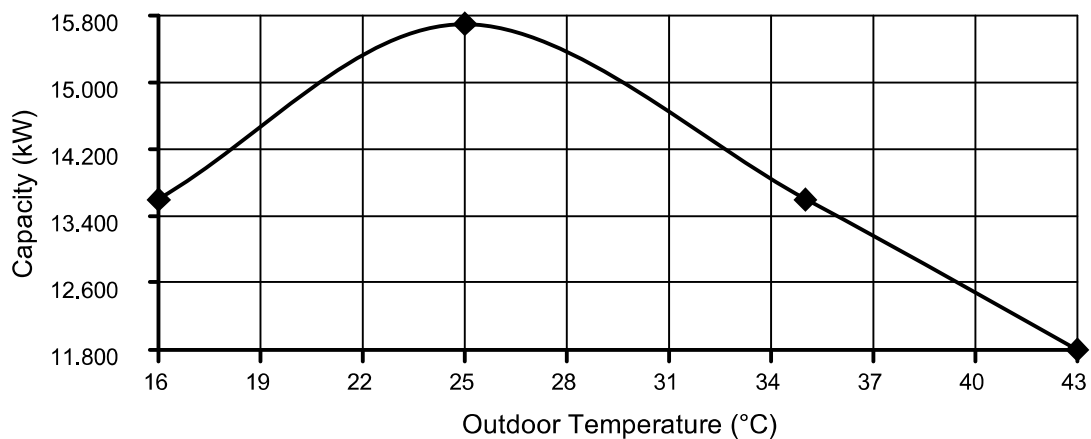

Cooling Characteristics at Different Outdoor Air Temperature

Condition

Outdoor air temperature : 35°C (DBT), -°C (WBT)

Indoor water inlet temperature : 23°C

Indoor water outlet temperature : 18°C

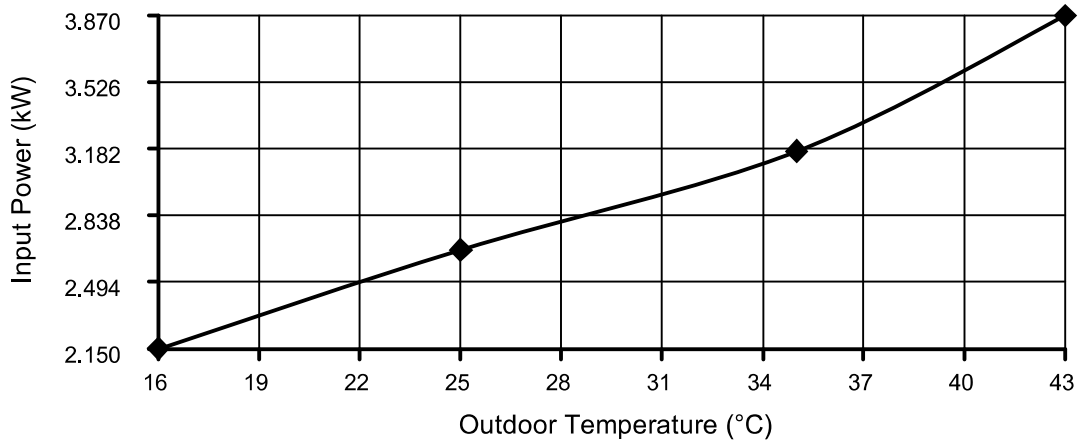
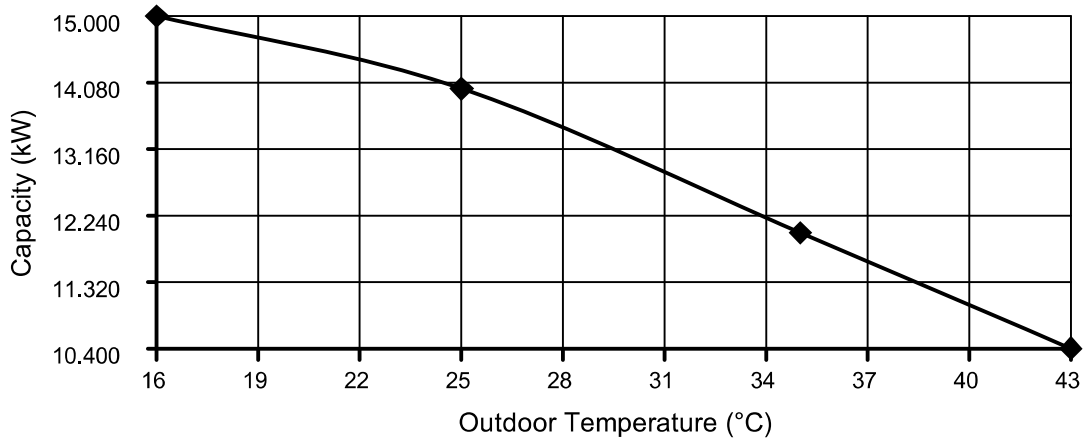

19.2 Heating Capacity Table

19.2.1 WH-MXC09J3E8

Water Out	25°C			35°C		
Outdoor Air	Capacity(W)	Input Power(W)	Current(A)	Capacity(W)	Input Power(W)	Current(A)
-20	9000	3440	5.1	9000	3950	5.9
-15	9000	2980	4.5	9000	3410	5.1
-7	10500	2720	4.1	9000	2920	4.4
2	10800	2140	3.2	9000	2360	3.5
7	9000	1380	2.1	9000	1770	2.6
25	9000	770	1.2	9000	1000	1.5

Water Out	45°C			55°C			60°C		
Outdoor Air	Capacity(W)	Input Power(W)	Current(A)	Capacity(W)	Input Power(W)	Current(A)	Capacity(W)	Input Power(W)	Current(A)
-20	9000	4650	6.9	7900	5580	8.3	-	-	-
-15	9000	4040	6.0	9000	4830	7.2	8700	5370	8.0
-7	9000	3540	5.3	9000	4240	6.3	9000	4620	6.9
2	9000	2910	4.3	9000	3550	5.3	9000	4050	6.1
7	9000	2370	3.5	9000	2920	4.4	9000	3290	4.9
25	10000	1670	2.5	10000	2280	3.4	11000	2860	4.3

Note:

* Between outdoor ambient -15°C and -20°C, the water outlet temperature gradually decreases from 60°C to 55°C.

* Only when ΔT is set to 15°C, the set temperature above 60°C will take effect.

19.2.2 WH-MXC12J9E8

Water Out	25°C			35°C		
Outdoor Air	Capacity(W)	Input Power(W)	Current(A)	Capacity(W)	Input Power(W)	Current(A)
-20	12000	5020	7.5	12000	5800	8.7
-15	12000	4140	6.2	12000	4830	7.2
-7	13500	4300	6.4	12000	4250	6.3
2	14500	3230	4.8	12000	3400	5.1
7	12000	2000	3.0	12000	2500	3.7
25	12000	1200	1.8	12000	1490	2.2

Water Out	45°C			55°C			60°C		
Outdoor Air	Capacity(W)	Input Power(W)	Current(A)	Capacity(W)	Input Power(W)	Current(A)	Capacity(W)	Input Power(W)	Current(A)
-20	10500	5750	8.6	9200	5800	8.7	-	-	-
-15	12000	5670	8.5	11100	6350	9.5	8700	6200	9.3
-7	12000	5020	7.5	12000	6000	9.0	11000	6300	9.4
2	12000	4200	6.3	12000	4950	7.4	12000	5770	8.6
7	12000	3240	4.8	12000	3940	5.9	12000	4520	6.8
25	12000	2100	3.1	12000	2750	4.1	12000	3110	4.6

Note:
 * Between outdoor ambient -15°C and -20°C, the water outlet temperature gradually decreases from 60°C to 55°C.
 * Only when ΔT is set to 15°C, the set temperature above 60°C will take effect.

19.3 Cooling Capacity Table

19.3.1 WH-MXC09J3E8

OD	Water Out 7°C			Water Out 14°C			Water Out 18°C		
	Capacity(W)	Input Power(W)	Current(A)	Capacity(W)	Input Power(W)	Current(A)	Capacity(W)	Input Power(W)	Current(A)
16	9000	1660	2.5	11000	1540	2.3	11400	1350	2.0
25	9000	2060	3.1	12600	2450	3.7	10500	1600	2.4
35	9000	2910	4.3	10900	3070	4.6	9000	2020	3.0
43	7200	3360	5.0	8700	3330	5.0	7300	2530	3.8

19.3.2 WH-MXC12J9E8

OD	Water Out 7°C			Water Out 14°C			Water Out 18°C		
	Capacity(W)	Input Power(W)	Current(A)	Capacity(W)	Input Power(W)	Current(A)	Capacity(W)	Input Power(W)	Current(A)
16	11400	2150	3.2	13600	2140	3.2	15000	2150	3.2
25	12000	2930	4.4	15700	3680	5.5	14000	2660	4.0
35	12000	4230	6.3	13600	4440	6.6	12000	3170	4.7
43	10300	5000	7.5	11800	5090	7.6	10400	3870	5.8